

# Challenge A: *viDio Adventure*

Focus: *Technical Design; International Current Events; Theater Arts; Teamwork*



## The Destination: *Where This Challenge Will Take You!*

Searching for love? A cure for cancer? Or just the perfect cheeseburger? Imagine that you and your team members are the modern day heroes of your own video adventure game, on a Quest to other Nations. As your Seeker journeys from Game Level to Game Level, it overcomes Obstacles and collects your Rewards in this 3-D adventure brought to life by you!

## Points of Interest

- ★ The team will create a Presentation that portrays a 3-Dimensional viDio Adventure game.
- ★ The team will design and construct a Seeker that will go on a Quest through three Nations.
- ★ The team will theatrically represent the Nations as Game Levels in the viDio game, send their Seeker to overcome an Obstacle at each Game Level, and receive a Reward Item needed to triumph in the Quest.
- ★ The team will conclude the story of the Quest using the Reward Items from each Nation.
- ★ The team will integrate an Improv Element and three *Side Trips* into their Presentation.

**Time Limit:** The team must complete the Presentation (including set up) in **eight minutes**.

**Team Budget:** The total value of the materials used in the Presentation may not exceed **\$150US**.

**Roadmap for Success:** Teams must read the *Rules of the Road* in order to successfully solve this Challenge!

## A. Itinerary: *The Central Challenge (225 points)*

1. **The Challenge:** The team's Presentation must tell the story of a modern day Quest by physically depicting a live 3-Dimensional viDio Adventure Game that takes place in three Nations. The viDio Game must have three Game Levels, each portraying a different Nation. The team must create a Seeker that will travel through the Game Levels. For each Game Level, the Seeker will leave from the Portal, travel to a Nation, overcome an Obstacle, and return to the Portal. Each time an Obstacle is overcome, the team may collect a Reward Item. The team ends their story in a Conclusion using the Reward Items they have collected.
2. **The viDio Game:** The team must create a Presentation that physically depicts a live 3-Dimensional (3-D) viDio adventure game.
  - a. The viDio Game's theme must tell a story of a modern day *Quest (C.6.)*, which must be set in the **recent past or present (1993 - 2003)**. It is the intent of the Challenge that teams learn about current events in their own and other *Nations (C.7.)*.
  - b. The Quest will consist of three *Game Levels (C.3.)* that represent the team's own Nation and two other Nations. The team's Nation is determined by the country in which the team is registered for Destination ImagiNation®.
  - c. At each Game Level, the team will theatrically portray the Nation through the use of dialogue, music, costuming, geographic features, scenery, props, background effects, etc. Teams will receive points at each Game Level for the overall Theatrical Effectiveness of the portrayal of the Nation. Props and scenery are allowed in the Game Zone, but while the Seeker is traveling in a Game Level, team members may use only the area outside the 9ft. x 9ft. (2.74m x 2.74m) Game Zone (see D) to tell the story of their Quest.

3. **The Seeker:** The team must design and build a *Seeker (C.14.)*. The design of the Seeker must allow it to journey from the Portal through each Game Level in the course of its Quest. It must also be designed to overcome one team-created Obstacle in each Game Level.
  - a. There are no minimum or maximum dimensions for the Seeker, but all floor contact points of the Seeker must fit completely inside the 2ft. x 2ft. (0.61m x 0.61m) Portal area (A.4.). A team member may not BE the Seeker or any part of the Seeker. Team members may provide power or indirectly manipulate the Seeker, but they may not physically be a part of the Seeker.
  - b. When the Seeker is in the Game Level area, the team must control it from outside the 9ft. x 9ft. (2.74m x 2.74m) Game Zone (D.), either by *indirect manipulation (C.4.)* or by *remote methods (C.11.)*. Although team members may reach across the Zone border line into the Game Zone, they may step across the line or directly touch the Seeker only when the Seeker is in the Portal.
  - c. The Seeker will be scored for *Technical Innovation (C.16.)* and *Technical Integration (C.17.)*, whether or not it successfully overcomes Obstacles (A.5.). Teams will also be awarded points for the appearance of the Seeker.
  
4. **The Portal:** The Seeker must leave the Portal to start each Game Level. The *Portal (C.10.)* is a 2ft.x 2ft. (2.74m x 2.74m) square in the center of the Game Zone. This Portal area is a *safe zone (C.13.)*
  - a. The Seeker may be placed in the Portal at any time after the timed Presentation begins. Team members may walk into the Game Zone to place the Seeker in the Portal for the first time.
  - b. The Seeker may move into and out of the Portal at any time in the game. The action at each Game Level will begin when the Seeker passes out of the Portal. The Game Level action will end when the Seeker passes back into the Portal.
  - c. If team members wish to enter the Game Zone to change or reset Obstacles, props, and scenery, to repair, modify or alter the Seeker, or for any other reason, they may do so **ONLY** when the Seeker is inside the Portal area. If a team member steps into the Game Zone or directly touches the Seeker when all its floor contact points are not inside the Portal area, the Seeker must return to the Portal and that Game Level must be restarted. There will be no deduction, but time will continue.
  
5. **Obstacles:** The Seeker must successfully overcome three team-created *Obstacles (C.8.)*, one in each Nation/Game Level. The action that overcomes the Obstacle must be initiated and completed by the Seeker. To minimize any chance of confusion, the team must clearly describe each Obstacle and how it will be overcome on the *Tournament Data Form*, found at the end of this Challenge. Once an Obstacle has been successfully overcome, the team will receive a Reward Item to use in the Conclusion of the Quest.
  - a. In the approximate center of each Game Level, as determined by the Appraisal Team, a 6in. x 6in. (0.15m x 0.15m) "X" will be taped on the floor (*See diagram in D.*). The team will place each Obstacle and its Reward Item (A.6.) anywhere on the taped "X." This "X" will remain in the same spot throughout the Tournament for all teams.
  - b. The team must create one Obstacle for each Game Level/Nation of their viDio Game from the choices below.
    - i. **Game Level One:** CHOOSE ONE: (0 or 15 points for completion)
      1. **Make a Noise:** The Seeker must cause a team-built Obstacle within Level One of the Game Zone to make a noise audible by an Appraiser at 20ft.(6.1m) The noise must originate from the Obstacle.
      2. **Pop Up or Drop Down:** The Seeker must cause some part of a team-built Obstacle within Level One of the Game Zone to "*pop up*" (C.9.) OR "*drop down*" (C.2.). In other words,

the Seeker will cause something to change from a horizontal plane to a vertical plane, or from a vertical plane to a horizontal plane, displaying a different surface.

- ii. **Game Level Two: CHOOSE ONE: (0 or 20 points for completion)**
    1. Elevate an Object: The Seeker must transport a solid physical object from the Portal area and place it on top of a team-built Obstacle with a minimum height of 2ft. (0.61m) from the floor of the Level Two area of the Game Zone. The Object must have at least one dimension that is a minimum of 3in.(0.08m).
    2. Combine Two Objects: The Seeker must transport two or more separate solid physical objects from the Portal to the "X" in Game Level Two and *combine* (C.1.) them together to create a single larger object. Each Object must have one minimum dimension of at least 6in. (0.15m).
  - iii. **Game Level Three: CHOOSE ONE (0 or 25 points for completion)**
    1. Jump: The body of the Seeker must *jump* (C.5.) over a team built 6in. (0.15m) square block within the Level Three area of the Game Zone. The entire body of the Seeker must leave the floor during the jump and no part of it may touch the block.
    2. Ramp: The Seeker must go up and over a team-constructed ramp with a minimum peak height of 1ft. (0.31m) within the Level Three area of the Game Zone
  - c. Obstacles with their Reward Items may be placed in the Game Zone, reset, or moved only when all floor contact points of the Seeker are within the Portal.
  - d. Each of the Obstacles will be objectively scored by the Appraisal Team for successful completion. An Appraiser will indicate successful completion of each Obstacle with a "thumbs up" signal to the team. The decision of the Appraisers is final.
  - e. If the Appraisal Team determines that the Obstacle is not successfully overcome, it is up to the team to determine why and decide whether or not to attempt the Obstacle again. There will be no deduction for repeated attempts, but time will continue. If the team chooses to not reattempt the Obstacle and moves on to the next Game Level, the team will not receive a Reward Item from that Game Level for use in the Conclusion.
  - f. The Seeker may only reattempt Obstacles not successfully overcome during the same Game Level. Once the Seeker has entered a different Game Level, it may not return to a previous Level to reattempt Obstacles that were not successfully overcome.
6. **Reward Items:** Once the Appraiser indicates that the Obstacle is *successfully overcome* (C.15.), the team will be considered to have won the team-created *Reward Item* (C.12.), and may use it during the Conclusion.
- a. The Reward Item must represent a **product or resource of the Nation being portrayed** at that Game Level.
  - b. The Reward Item must be placed with the Obstacle in the Game Zone while the Seeker is within the Portal area. The Reward Item must be touching the Obstacle. It may be affixed, connected to, or balanced on any part of the Obstacle in any manner that the team chooses.
  - c. When the Obstacle is successfully overcome, and after the Seeker has returned to the Portal Area, the team may then collect the Reward Item. (Remember – team members may not step into the Game Zone until the Seeker has returned to the Portal area! If a team member steps into the Game Zone to collect the Reward Item while the Seeker is outside the Portal Area, the Seeker must return to the Portal and that Game Level must be restarted and the Obstacle overcome again.)

7. **And The Story Ends:** The team will present the Conclusion to their Quest.
  - a. The team's story line should have a beginning and middle that leads to the Quest's Conclusion in the end. The team will be awarded points for the development of the Quest's story line (including the Conclusion) throughout the Presentation.
  - b. The Reward Items that the Seeker has successfully collected from the Nations must be utilized in the story of the Conclusion of the team's Quest.
  - c. Teams may use the entire Performance Site (including the Game Zone) for this portion of the Presentation; however, once this portion of the Presentation begins, the Seeker may no longer overcome Obstacles or collect Reward Items for scoring.
  - d. The Seeker may be included in the Conclusion to the Quest, but must have entered the Portal area at the end of the last Game Level before exiting for the Conclusion.
  
8. **Improv Element:** At the Tournament, each team will choose from two types of Improv Elements to integrate into their Presentation: An **Improv Item** or the **Improv Alternate**.
  - a. **Improv Item:** An Improv Item is an ordinary physical object that the team will use as a prop in their Presentation. One minute before their Presentation begins the team will find out what the Item is. It may not be changed from its original form during the team's Presentation.
  - b. **Improv Alternate:** For this Program year, the Improv Alternate asks teams to **Create a Phrase** and integrate the Phrase into their Presentation. One minute before their Presentation begins, the team will randomly select three letters of the alphabet. The team will then be given one minute to create a three-word Phrase in which the first letter of each word is one of the three letters they have chosen. For example, if the letters chosen were S, T, L, the team might create the Phrase "Leave The School." The team must use all three letters, but team members do not have to use the letters in the order they were selected. However, once the team creates the Phrase, they may not change the Phrase or the order of the words. The words chosen by the team must be real (not nonsense) words in whatever language is the primary language used at the Tournament.
  - c. The intent of the Improv Element is for the team to improvise and use the Item or Phrase in a meaningful way during the course of the Presentation. The team will be awarded up to 25 points, depending on how well the Improv Element is used in the Performance. More information about the Improv Element is provided in the *Rules of the Road* and the *Team Manager Guide*.
  
9. **Team Identification Sign:** Your team must provide a free-standing Identification Sign (ID Sign) of approximately 2ft. (.6m) x 3ft. (.9m) displaying your team's Passport Name, Passport Number, and Level. It may not be used as a scoring element. See "Team Identification Sign" section in *Rules of the Road* for further information.

## B. *Side Trips* (75 points)

The team must present three creations called '*Side Trips*.' *Side Trips* give teams a chance to really show off their Specialties, which are their skills, interests, areas of strength, and talents. **The team may create anything they wish for *Side Trips*** including props, music, technical gadgets, costumes, and physical actions.

1. The team must present all three *Side Trips* as part of the timed Presentation. Each *Side Trip* must be described briefly on the *Tournament Data Form* found at the end of this Challenge.
2. A *Side Trip* may not be a specific item that is required in the Central Challenge that is already being evaluated. A *Side Trip* MAY be a single unique PART of a required item, as long as it can be evaluated as a stand-alone item. Two *Side Trips* may be presented at the same time ONLY IF both can be easily identified and scored separately. Examples of these can be found in the *Rules of the Road*.
3. Each *Side Trip* is worth 25 points and will be evaluated in two ways: The creativity and originality of the *Side Trip*, and the quality, workmanship, and/or effort that is evident. Evaluation of *Side Trips* is subjective.

## C. Special Definitions for this Challenge

1. **Combine:** To join, affix, bond, or attach together in any manner.
2. **Drop Down:** To change from a vertical plane to a horizontal plane, displaying a different surface.
3. **Game Level:** Game task area, each representing a Nation. Each Game Level has a specific space within the Game Zone, marked with an "X," where the Obstacle at that Level must be set and overcome.
4. **Indirect Manipulation:** Movement or action caused by team members manipulating the Seeker without having direct physical contact with it.
5. **Jump:** When all floor contact points of the Seeker leave the floor.
6. **Quest:** A journey of discovery and adventure in search of something special.
7. **Nation:** Any real modern-day country, clearly identified on a current (1993 or later) geopolitical map. The team's own Nation must be one of three represented in the viDio Game. The team's nation is determined by the country in which the team is registered for Destination ImagiNation®.
8. **Obstacle:** A task that must be completed.
9. **Pop up:** To change from a horizontal plane to a vertical plane, displaying a different surface.
10. **Portal:** a safe zone where the Seeker begins the game and exits to begin a new Game Level.
11. **Remote Methods:** Movement or action, in which the Seeker is manipulated without any physical contact, direct or indirect, at all.
12. **Reward Item:** A prize or bonus representing a product or resource of the Nation being portrayed. These are considered to be "won" once each Obstacle is successfully overcome. The Reward Items must be used in the conclusion of the story of the Quest.
13. **Safe Zone:** The Portal area; team members may enter the Game Zone only while the Seeker is in this area.
14. **Seeker:** An apparatus operated by remote or indirect manipulation of controllers outside the 9ft. x 9ft. (2.74m x 2.74m) Game Zone.
15. **Successfully Overcome:** Occurs when the Seeker has overcome the Obstacle (accomplished the task) as determined by a member of the Appraisal Team. Successfully overcoming the Obstacle will be indicated to the team by a "thumbs up" signal.
16. **Technical Innovation:** A new, original, or creative way to carry out or accomplish a task using technical methods.
17. **Technical Integration:** How individual parts or devices work together to form a unified system. In a well-integrated system, each part or device will have a purpose and be necessary to the proper working of the system.

## D. Performance Site

1. The Performance Site will be a minimum of 15ft. x 15ft. (4.57m x 4.57m). When possible, larger performance areas will be provided.
2. Teams may use all the performance space available at their site, but they must be prepared to perform in the minimal area specified.
3. If possible, the Tournament Director will provide a minimum two-foot buffer area between the Performance Site and any walls or audience.
4. No alterations to the Performance Site will be permitted.
5. The solid lines in the diagram below represent the taped Game Zone. The entire Performance Site will not be taped.

GAME ZONE DIAGRAM

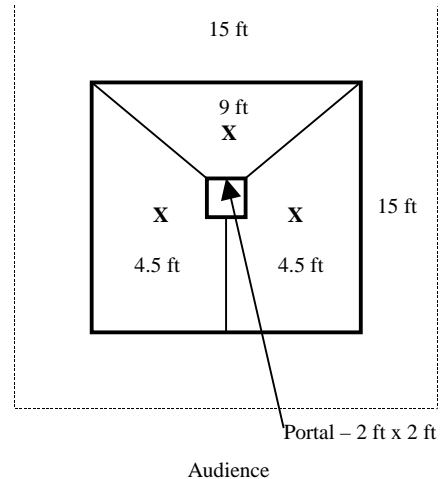

## E. Reward Points

ELEMENT	POINTS	DETAIL
<b>I. Central Challenge</b>	<b>225 points</b>	
1. Effective Theatrical Representation of Nations	<b>3-60</b>	<b>A.2.</b>
a. Nation depicted in Game Level One	1- 20	A.2.c.
b. Nation depicted in Game Level Two	1- 20	A.2.c.
c. Nation depicted in Game Level Three	1- 20	A.2.c.
2. The Seeker	<b>2-50</b>	<b>A.2</b>
a. Technical Innovation and Integration	1-40	A.2.e
b. Appearance	1-10	A.2.g
3. Successfully Overcoming the Obstacles	<b>0-60</b>	<b>A.4</b>
a. Obstacle 1: Noise           or   Pop Up/Drop Down	0 or 15	A.4.d.i
b. Obstacle 2: Elevation   or   Combination	0 or 20	A.4.d.ii
c. Obstacle 3: Jump       or   Ramp	0 or 25	A.4.d.iii
4. "The Story Ends"	<b>2-30</b>	<b>A.6</b>
a. Development of Storyline (including Conclusion)	1-20	A.6.a
b. Reward Items used in Conclusion	1-10	A.6.b
5. Improv Element	<b>1-25</b>	A.8.
<b>II. Side Trips – 1, 2, 3</b>	<b>1-25 each</b>	<b>C</b>
	<b>75 total</b>	
1. Creativity and Originality	1-15	C.3.
2. Quality, Workmanship, or Effort that is evident	1-10	C.3.

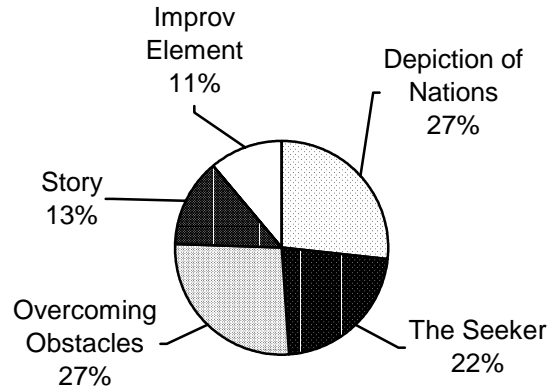

## F. Important Directions for Team Managers

1. **Teams and Team Managers will be expected to read** the *Rules of the Road*, the *TravelGuide for Teams*, and the Published Clarifications for this *Team Challenge*. The information provided in these resources is binding on all teams. All materials can be found on the Destination ImagiNation® website: [www.destinationimagination.org](http://www.destinationimagination.org) or by contacting your Coordinator. The *TravelGuide for Teams* will be available online after January 1, 2003.
2. **Teams often have questions about the *Team Challenge*.** The answers to these questions are called Clarifications, and Clarifications that impact all teams are listed on the Destination ImagiNation® website. *Such Clarifications supersede the written Challenge.* ALL TEAMS and Team Managers need to check the listed Clarifications frequently throughout the year. For more information about Clarifications, see *Rules of the Road*.

**REMEMBER:** IF the team has read the Challenge, and IF they have checked the Rules of the Road, and IF they have checked the Published Clarifications, and it doesn't say they can't do something, THEN THEY CAN!

3. **Team Managers will find everything they need to know** to manage a team successfully in the *Team Manager's Guide*. Team Managers are strongly encouraged to read and use this Guide which is full of ideas, activities, and helpful hints. It can be found on the Destination ImagiNation® website.
4. **Teams and individuals using this *Team Challenge* must hold a 2002-03 Passport.** The Destination ImagiNation® Passport is a license to compete in sanctioned Tournaments and/or to use the Destination ImagiNation® *Team Challenges*, *Rules of the Road* and other program materials for educational purposes within your team, school, group, or organization. All Destination ImagiNation® Program materials are copyrighted. Teams or individuals using these materials are liable for all legal obligations and must abide by all the rules of competition and safety as stated in the 2002-03 *Team Challenges* and *Rules of the Road*.
5. **Each team planning to compete in a sanctioned Tournament must REGISTER** for that Tournament in advance with their Region or Affiliate. If your Program Coordinator has not already received a *Tournament Registration Form* for Teams, ask your Affiliate Director for the contact person in your Region, State, Province or Country who can provide Tournament registration information. A full list of Affiliate Directors is posted on the Destination ImagiNation® web site.

# Tournament Data Form

# Challenge A: *viDio Adventure*

Page 1 of 2

**Passport Name:** \_\_\_\_\_ **Passport Number** \_\_\_\_\_ **Level:** EL ML SL UL

**To our Teams and Team Managers:** The purpose of this form is to help your Appraisers identify the required elements of your Challenge solution. It is important to fill it out completely and **neatly**. For Elementary Level teams only: Team Managers MAY fill out the form, writing out the words dictated by the team.

**PART ONE: Required Paperwork:** At the Tournament Performance Site, the Prep Area Appraiser will ask for your team's forms. A complete checklist of the required forms is below.

**Your team needs:**

- \_\_\_\_\_ **Five copies** of this completed two-page *Tournament Data Form*. **Be sure to copy both pages of this form.** Page two **may** be copied onto the back of this form.
- \_\_\_\_\_ **Two Copies** of the *Declaration of Independence*. (One copy will go to the Prep Area Appraiser, one copy to the Instant Challenge Appraisers.) Blank copies of this form can be found in the *Rules of the Road* and at the Destination ImagiNation® web site: [www.destinationimagination.org](http://www.destinationimagination.org)
- \_\_\_\_\_ **One Copy** of the *Expense Report*. This form can be found in the *Rules of the Road* and can also be downloaded from the Destination ImagiNation® web site: [www.destinationimagination.org](http://www.destinationimagination.org). Be sure to bring copies of your receipts, but it is not necessary to attach them to the form.
- \_\_\_\_\_ **Team Identification Sign:** This will tell the Appraisers and the audience who you are. It must list your Passport Name, Passport Number, and Level. It will **not** be scored. See the *Rules of the Road* for more information.

**PART TWO: Side Trip Choices:**

**Brief Description of each Side Trip:** Briefly tell the Appraisers about the *Side Trips* your team has prepared. Make sure that Appraisers know **exactly** what you want them to evaluate. What would you like them to know about each *Side Trip*?

**Side Trip 1:** \_\_\_\_\_  
**Description:**

**Side Trip 2:** \_\_\_\_\_  
**Description:**

**Side Trip 3:** \_\_\_\_\_  
**Description:**

# Tournament Data Form

# Challenge A: *viDio Adventure*

Page 2 of 2

Passport Name: \_\_\_\_\_ Passport Number: \_\_\_\_\_ Level: EL ML SL UL

**PART THREE:** This Challenge requires the team to supply the following information to help the Appraisers evaluate your solution. This is PAGE TWO of the form. Be sure to fill in both pages.

1. **What is the story of your modern-day Quest?** Give a brief (50 words or less) synopsis of your viDio Game in the space below. Also tell in what year or years between 1993-2003 your story takes place.

2. **Briefly describe your Seeker and how it works.**

3. **Level One:**

- a. Nation: \_\_\_\_\_
- b. Reward Item for this Nation: \_\_\_\_\_
- c. Obstacle: Circle the Obstacle your team created.      Make a Noise      Pop Up or Drop Down
- d. Please tell how the Seeker will overcome the Obstacle:

4. **Level Two**

- a. Nation: \_\_\_\_\_
- b. Reward Item for this Nation: \_\_\_\_\_
- c. Obstacle: Circle the Obstacle your team created.      Elevate an Object      Combine Two Objects
- d. Please tell how the Seeker will overcome the Obstacle:

5. **Level Three**

- a. Nation: \_\_\_\_\_
- b. Reward Item for this Nation: \_\_\_\_\_
- c. Obstacle: Circle the Obstacle your team created.      Jump      Ramp
- d. Please tell how the Seeker will overcome the Obstacle: